

**Haldex**

## F20LS/F30LS FERRA SERIES LOAD SENSE PUMP



## The Load Sensing Concept

Load Sensing is a hydraulic circuit configuration which allows the load, as sensed at the control valve, to modulate pump output in relation to system demand. Controlling both flow and pressure at the pump allows for a significant reduction in valving losses and circuit inefficiencies. The machine is therefore more efficient in terms of power distribution and life is enhanced due to superior load control.

- \* Improved Hydraulic System Efficiency
- \* Improved Vehicle Life
- \* Efficiently Sized Componentry

## Benefits of Load Sensing Systems

Load Sensing Systems have been applied to hydraulic applications, in several configurations, to provide efficiency and performance advantages over standard circuit designs. Load sensing piston pumps or load sensing unloading valves have typically been used in these applications. Haldex has developed a load sensing gear pump to combine the advantages of these two technologies. The F20LS (1.41 - 5.30 in.<sup>3</sup>) and the F30LS (3.54 - 9.82 in.<sup>3</sup>) provide the following advantages to your machine:

- \* Lower Fuel and Input Power Consumption
- \* Cooler Hydraulic System Operation
- \* Longer Component Life and Reliability
- \* Improved Vehicle Power Distribution
- \* Better Load Control

## Design Advantages of F20LS and F30LS Pumps

The simplicity and inherent advantages of the gear pump design are realized with the F20LS and F30LS. The F20LS and F30LS feature the operational benefits of a piston pump with the performance, reliability, and cost advantages of a gear pump.

- \* Lower Pump Cost
- \* 4000 PSI Continuous Pressure Rating
- \* High Speed Capability
  - Up to 4000 RPM
- \* Displacement Flexibility
  - 1.41 to 9.82 in.<sup>3</sup>/rev.
- \* Gear Pump Serviceability
- \* Added Tolerance Under Extreme Operating Conditions
  - Contaminated Environments
  - High Temperatures
  - Cold Start-Ups
  - Poor Inlet Circumstances
- \* Ultra Quick Response Time to Load Sense Signal
  - 100 milliseconds or Less

## How the F20LS and F30LS Pumps Operate

Every hydraulic application has two known operating conditions - **running** (when hydraulic flow is required) and **standby** (when no hydraulic flow is required).

### Running Condition:

In the running condition, the F20LS/F30LS load sensing element continuously monitors the output flow required for the system load demand. The pump alters its flow at the pump and matches the system load demand and delivers the exact flow required. Flow regulation at the pump eliminates efficiency losses associated with alternative systems which alter flow at the directional valve and regulate system pressure with a system relief valve.

### Standby Condition:

In the standby condition, the load sensing element senses a zero demand condition and unloads all flow directly to the system's reservoir. In the standby condition, flow is unloaded at approximately 20 PSI, hence, greatly reducing horsepower consumption and system heat.

The chart below illustrates the horsepower conservation advantages of the F20LS/F30LS pump when compared to the common alternative system designs of a piston pump and a standard open center valve/gear pump combination.

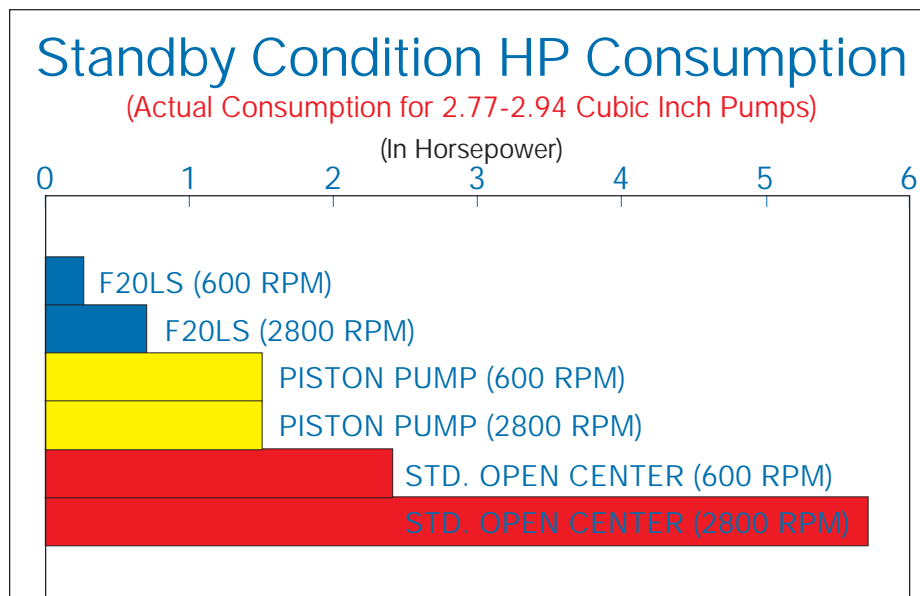

NOTE: In the standby condition, piston pumps operate at 200-500 PSI and produce 1-2 GPM for internal lubrication purposes. This condition results in higher horsepower consumption than the F20LS / F30LS at standby.

## Where to Apply the F20LS and F30LS Pumps

### Mobile Applications

The F20LS and F30LS are best applied in mobile applications where the vehicle duty cycle is concentrated in either the full speed or the standby condition. The F20LS and F30LS are ideal choices for vehicles which have extended transport or "roading" modes. Examples of these types of vehicles would include tractors, wheel loaders, snow and ice removal trucks and many others. Significant horsepower savings as described above is achieved during the standby mode. The F20LS / F30LS may not have advantages over the piston pump in applications where flow must be continuously "metered", consequently the selection of these pumps is dependent upon the application.

### Industrial Applications

The F20LS and F30LS can also be used in many industrial type hydraulic applications to simplify and cost reduce traditional circuits. General load sensing, accumulator unload, vented relief valve, multiple relief valve and other types of circuits can all be simplified and cost reduced by using the F20LS and F30LS pumps. These circuits typically use expensive unloader or vented relief valves and the F20LS and F30LS can reduce system costs by 50% or more by incorporating the load sensing feature in the pump and using significantly less expensive standard directional control valves. (Associated installation costs are also reduced because of the circuit simplification achieved by using the F20LS and F30LS along with standard directional control valving.)

# F20LS Specifications and Application Data

Single Model Series	Gear Code	Flow @ 1800 RPM		Theoretical displacement per revolution		Continuous Rated pressure		Rated speed @ pressure & .17 bar (6" Hg) vacuum inlet rpm	Unloaded speed @ max. speed rpm	Min. speed @ rated pressure rpm*	Typical delivery @ rated speed & pressure	
		l/min	gpm	cm <sup>3</sup>	in <sup>3</sup>	bar	psi				l/min	gpm
F20LS	23	41.6	11	23	1.41	276	4000	3600	4000	1000	75.7	20
	29	53.0	14	29	1.79	276	4000	3400	4000	800	90.8	24
	36	64.3	17	36	2.18	276	4000	3200	4000	600	105.9	28
	43	75.7	20	43	2.60	276	4000	3000	4000	600	117.3	31
	48	87.0	23	48	2.94	276	4000	2800	4000	600	124.9	33
	55	98.4	26	55	3.33	250	3625	2500	4000	600	128.7	34
	62	109.8	29	62	3.77	228	3300	2500	4000	600	147.6	39
	68	121.1	32	68	4.13	228	3000	2500	4000	600	162.7	43
	77	140.0	37	77	4.71	190	2700	2500	4000	600	185.4	49
	87	155.2	41	87	5.30	170	2375	2300	4000	600	193.0	51

Design flow control should be based on  $\Delta P$  of 200 PSI across the control orifice. **Adjustable Bias Factory Set at 200 PSI (14 BAR).** Adjustable System Relief Valve from 1000 - 3000 PSI (69 - 207 BAR) in 250 PSI (15 BAR) increments and from 3000 - 4000 PSI (69 - 276 BAR) in 500 PSI (35 BAR) increments.

\* Lower speeds are permissible when operating below rated pressure.

## F20LS Drive Shafts

### SAE "B" SPLINE

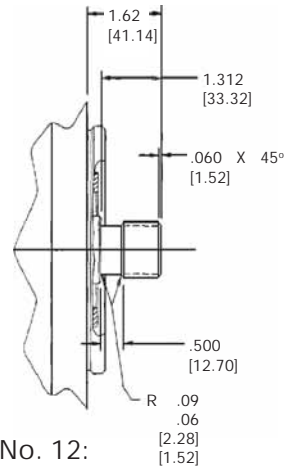

External Involute Spline  
Flat Root-Side Fit  
No. of Teeth - 13  
Dia. Pitch - 16/32  
Pressure Angle 30°

Shaft No. 12:  
279.6 Nm (2475 in.lb.) torsional capacity.\*

### SAE "BB" STRAIGHT KEY

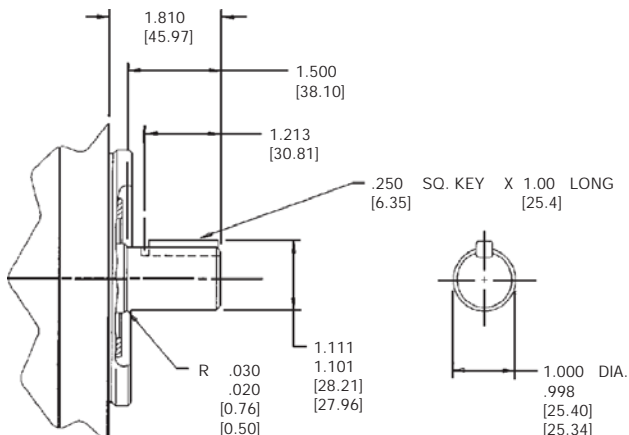

Shaft No. 21:  
395.7 Nm (3500 in.lb.) torsional capacity.\*

### SAE "BB" SPLINE

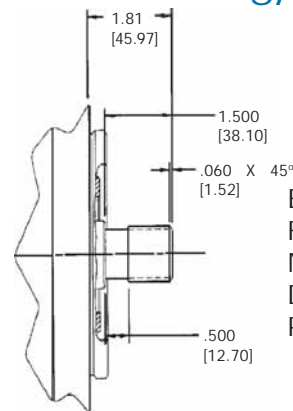

External Involute Spline  
Flat Root-Side Fit  
No. of Teeth - 15  
Dia. Pitch - 16/32  
Pressure Angle 30°

Shaft No. 99:  
451.9 Nm (4000 in.lb.) torsional capacity.\*

\* Consult representative if application requires greater capacity or has side loads.

# F20LS Installation Dimensions

Inches (mm)

Mounting flange dimensions shown are for SAE "B" 2-Bolt.

SAE "A" flange is also available.

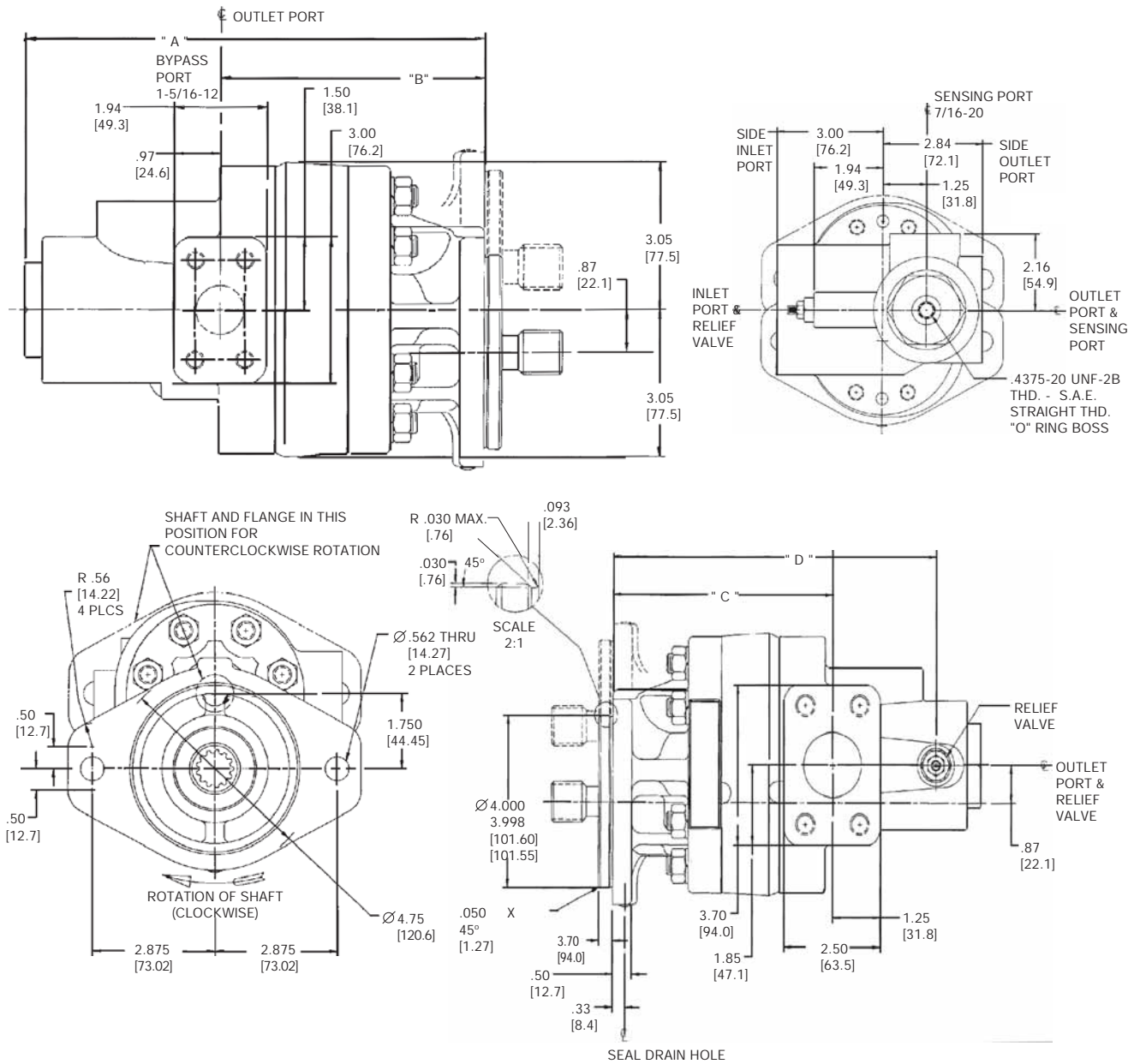

Model	" A " Inch (mm)	" B " Inch (mm)	" C " Inch (mm)	" D " Inch (mm)	App. Wt. Lbs. (kg)
F20LS-2*23*-**-**	9.03 (229.4)	4.63 (117.6)	4.85 (123.2)	7.67 (194.9)	35.4 (15.65)
F20LS-2*29*-**-**	9.21 (233.9)	4.81 (122.2)	5.03 (127.8)	7.85 (199.4)	35.0 (15.88)
F20LS-2*36*-**-**	9.39 (238.5)	4.99 (126.8)	5.21 (132.3)	8.03 (204.0)	35.1 (15.92)
F20LS-2*43*-**-**	9.58 (243.3)	5.18 (131.6)	5.40 (137.2)	8.22 (208.8)	36.5 (16.56)
F20LS-2*48*-**-**	9.74 (247.4)	5.34 (135.6)	5.56 (141.2)	8.38 (212.9)	37.0 (16.78)
F20LS-2*55*-**-**	9.91 (251.7)	5.51 (140.0)	5.73 (145.5)	8.55 (217.2)	37.6 (17.06)
F20LS-2*62*-**-**	10.11 (256.8)	5.71 (145.0)	5.93 (150.6)	8.75 (222.3)	38.0 (17.24)
F20LS-2*68*-**-**	10.28 (261.1)	5.88 (149.4)	6.10 (154.9)	8.92 (226.6)	39.0 (17.69)
F20LS-2*77*-**-**	10.55 (268.0)	6.15 (156.2)	6.37 (161.8)	9.19 (233.5)	40.0 (18.14)
F20LS-2*87*-**-**	10.82 (274.8)	6.42 (163.1)	6.64 (168.7)	9.46 (240.3)	41.8 (18.96)

# F30LS Specifications and Application Data

Single Model Series	Gear Code	Flow @ 1800 RPM		Theoretical displacement per revolution		Continuous Rated pressure		Rated speed @ pressure & .17 bar (6" Hg) vacuum inlet rpm	Unloaded speed max. speed rpm	Min. speed @ rated pressure rpm*	Typical delivery @ rated speed & pressure	
		l/min	gpm	cm <sup>3</sup>	in <sup>3</sup>	bar	psi				l/min	gpm
F30LS	58	94.0	24.8	58	3.54	276	4000	3000	4000	600	156.9	41.4
	68	109.9	29.0	68	4.13	276	4000	3000	4000	600	183.1	48.3
	80	130.4	34.4	80	4.91	276	4000	3000	4000	600	217.6	57.4
	91	146.7	38.7	91	5.51	276	4000	2750	4000	600	223.6	59.0
	97	156.9	41.4	97	5.89	276	4000	2500	4000	600	217.6	57.4
	104	167.5	44.2	104	6.30	250	3625	2500	4000	600	232.7	61.4
	113	183.4	48.3	113	6.88	250	3400	2500	3700	600	233.9	61.0
	129	208.8	55.1	129	7.86	228	2900	2400	3300	600	278.6	73.5
	145	239.0	62.0	145	8.84	190	2550	2300	2900	600	300.2	79.2
	161	261.1	68.9	161	9.82	170	2300	2200	2500	600	319.1	84.2

Design flow control should be based on  $\Delta P$  of 200 PSI across the control orifice. Adjustable Bias Factory Set at 200 PSI (14 BAR). Adjustable System Relief Valve from 1000 - 3000 PSI (69 - 207 BAR) in 250 PSI (15 BAR) increments and from 3000 - 4000 PSI (69 - 276 BAR) in 500 PSI (35 BAR) increments.

\* Lower speeds are permissible when operating below rated pressure.

## F30LS Drive Shafts

### SAE "C" STRAIGHT KEY

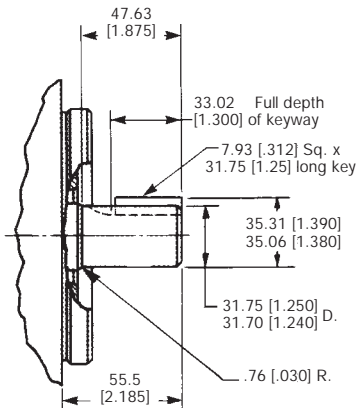

Shaft No. 1:  
720.8 Nm (6380 in. lb.) torsional capacity.\*

### SAE "C" SPLINE

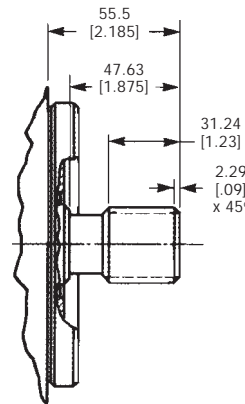

External Involute Spline  
Flat Root - Side Fit  
No. of Teeth - 14  
Diametral Pitch - 12/24  
Pressure Angle - 30°

Shaft No. 12:  
819.1 Nm (7250 in. lb.) torsional capacity.\*

### SAE "B" SPLINE

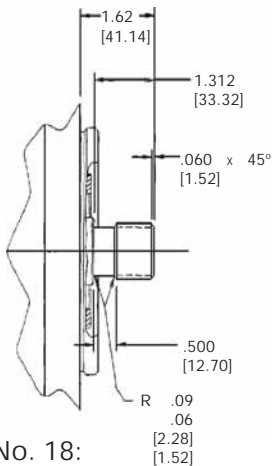

External Involute Spline  
Flat Root - Side Fit  
No. of Teeth - 13  
Diametral Pitch - 16/32  
Pressure Angle - 30°

Shaft No. 18:  
279.6 Nm (2475 in. lb.) torsional capacity.\*

#### NOTES:

Shaft #18 only available with displacements 58 and 68.

Contact factory for other shaft requirements not listed.

\* Consult representative if application requires greater torsional capacity or has side loads.

# F30LS Installation Dimensions

Inches (mm)

Mounting flange dimensions shown are for SAE "C" 4-Bolt.

Other SAE "B" and SAE "C" flanges are also available.

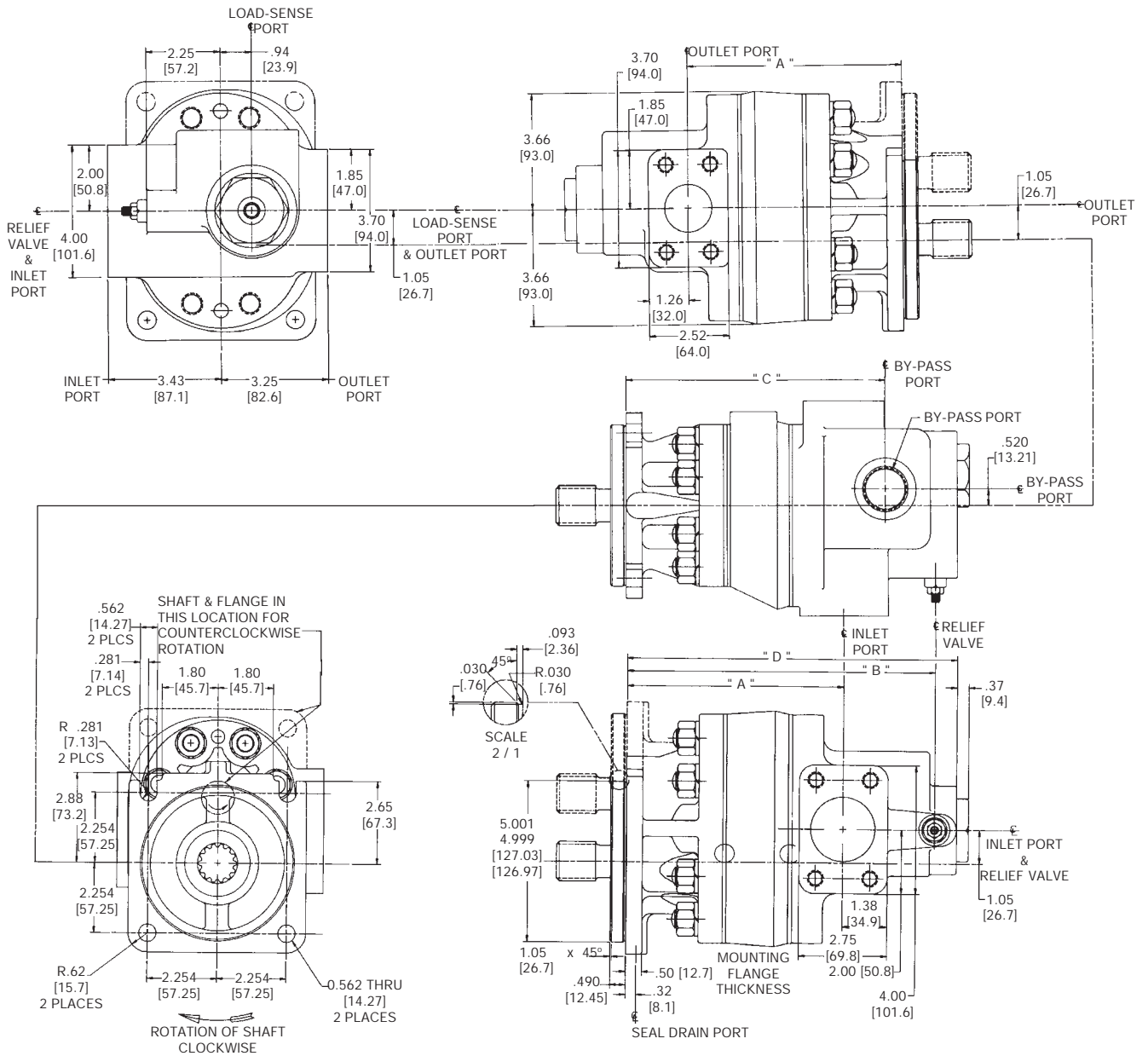

Model	"A" Inch (mm)	"B" Inch (mm)	"C" Inch (mm)	"D" Inch (mm)	App. Wt. Lbs. (kg)
F30LS-4E58**_*_*_*_*_*_*_*_*	5.96 (151.4)	8.81 (223.8)	7.26 (184.4)	9.49 (241.0)	52.3 (23.7)
F30LS-4E68**_*_*_*_*_*_*_*_*	6.15 (156.2)	9.00 (228.6)	7.45 (189.2)	9.68 (245.9)	53.1 (24.1)
F30LS-4E80**_*_*_*_*_*_*_*_*	6.39 (162.3)	9.24 (234.7)	7.69 (195.3)	9.92 (151.0)	55.1 (25.0)
F30LS-4E91**_*_*_*_*_*_*_*_*	6.55 (166.2)	9.40 (238.8)	7.85 (199.4)	10.08 (256.0)	56.3 (25.5)
F30LS-4E97**_*_*_*_*_*_*_*_*	6.70 (170.2)	9.55 (242.6)	8.00 (203.4)	10.23 (259.8)	57.5 (26.1)
F30LS-4E104**_*_*_*_*_*_*_*_*	6.86 (174.1)	9.71 (246.6)	8.16 (207.3)	10.39 (263.9)	58.5 (26.5)
F30LS-4E113**_*_*_*_*_*_*_*_*	7.01 (178.1)	9.86 (250.4)	8.31 (211.1)	10.54 (267.7)	60.1 (26.6)
F30LS-4E129**_*_*_*_*_*_*_*_*	7.32 (185.9)	10.17 (258.3)	8.62 (210.9)	10.85 (275.6)	61.7 (28.0)
F30LS-4E145**_*_*_*_*_*_*_*_*	7.63 (193.8)	10.48 (266.2)	8.93 (226.8)	11.16 (283.5)	64.3 (29.2)
F30LS-4E161**_*_*_*_*_*_*_*_*	7.94 (201.7)	10.79 (274.1)	9.24 (234.7)	11.47 (291.3)	66.5 (30.2)

# How To Order F20LS Series Pumps

## ORDERING INFORMATION

Each option has been assigned an order code -- listed in the tables below -- for placement in the sequence shown at right.

### 1 (Special Seals)

Order Code	Description
F3	Viton Seal
Omit	Standard

### 2 (Pump type)

Order Code	Description
F	Ferra Series Gear Pump

### 3 (Series)

Order Code	Description
20LS	F20 Load Sense **

### 4 (Mounting Flange)

Order Code	Description
1	SAE "A" 2-Bolt Flange
2	SAE "B" 2-Bolt Flange
6	SAE "B" 2 & 4-Bolt Combination Flange

### 5 (Inlet Port Connections)

Order Code	Description
A	43 cc & Under (2.6 in. <sup>3</sup> ) displacement - SAE 1.875-12
B	48 cc & Over (2.9 in. <sup>3</sup> ) displacement - 4-Bolt 1-1/2"

### 6 (Displacement)

Order Code	Cm <sup>3</sup> /In <sup>3</sup>	Order Code	Cm <sup>3</sup> /In <sup>3</sup>
23	23/1.41	55	55/3.33
29	29/1.79	62	62/3.77
36	36/2.18	68	68/4.13
43	43/2.60	77	77/4.71
48	48/2.94	87	87/5.30

### 7 (Outlet Port Connections)

Order Code	Description
A	43 cc & Under (2.6 in. <sup>3</sup> ) displacement - #16 SAE (1.3125"-12)
B	48 cc & Over (2.9 in. <sup>3</sup> ) displacement - 1", SAE 4-Bolt

ByPass Port:	1 5/16-12 for all sizes
Load Sense Port:	7/16-20 for all sizes

### 8 (Shaft Seal)

Order Code	Description
A	Single
B	Double
J	Double, Outer Inverted
X	None

\*\* Multiple pumps available. Contact factory.

EXAMPLE:

(F3)- F-20LS-1-A-23- A-A-1-A-L-25											
1	2	3	4	5	6	7	8	9	10	11	12
Special Seals	Pump Type	Series	Mounting	Inlet Port	Displacement	Outlet Port	Shaft Seal	Shaft Type	Unload Pressure	Shaft Rotation	R. V. Setting

### 9 (Shaft Types)

Order Code	Description
1	SAE "B" Straight Keyed, .875" dia., 1.312" ext.
11	SAE "B" 13 Tooth Spline (Major Diameter Fit)
12	SAE "B" 13 Tooth Spline (Flat Root-Side Fit)
21	SAE "BB" Straight Keyed 1" dia., 1.50" ext.
99	SAE "BB" 15 Tooth Spline (Flat Root-Side Fit)

Contact factory for other requirements.

### 10 (Unload Pressure)

Order Code	Description
A	18 PSI Standard Bypass Spring
B *	45 PSI Bypass Spring

\* "B" unload spring option required when system contains a high rate compensator in the directional control valve.

### 11 (Shaft Rotation)

Order Code	Description
L	Counterclockwise
Omit	Clockwise

### 12 (Relief Valve Setting)

Order Code	Description
10	1000 PSI (69 BAR)
12	1250 PSI (86 BAR)
15	1500 PSI (103 BAR)
17	1750 PSI (121 BAR)
20	2000 PSI (138 BAR)
22	2250 PSI (155 BAR)
25	2500 PSI (172 BAR)
27	2750 PSI (190 BAR)

### 13 (Load Sense Options)

Order Code	Description
A	Standard Load Sense
B	12 VDC with Spade Connector
C	24 VDC with Type C Connector
D	120 VAC with Type C Connector
E	240 VAC with Type C Connector

### 14 (Design Designation)

Order Code	Description
10	
└───┬───	Modification Level
└───┬───	Design Level

Standard factory relief valve setting is 2500 PSI (172 BAR).  
Contact factory for other settings.



# How To Order F30LS Series Pumps

## ORDERING INFORMATION

Each option has been assigned an order code -- listed in the tables below -- for placement in the sequence shown at right.

### 1 (Special Seals)

Order Code	Description
F3	Viton Seal
Omit	Standard

### 2 (Pump Type)

Order Code	Description
F	Ferra Series Gear Pump

### 3 (Series)

Order Code	Description
30LS	F30 Load Sense **

### 4 (Mounting Flange)

Order Code	Description
4	SAE "C" 4-Bolt Mount
6	SAE "B" 2 & 4-Bolt Combination Mount (consult factory)
7	SAE "C" 2-Bolt Mount
8	SAE "C" 2 & 4-Bolt Combination Mount

### 5 (Inlet Port Connections)

Order Code	Description
D	1.50", SAE 4-Bolt Split Flange
DM	1.50", 4-Bolt Metric Split Flange (M12 x 1.75" Threads)
E	2.00", SAE 4-Bolt Split Flange
EM	2.00", 4-Bolt Metric Split Flange (M12 x 1.75" Threads)
W	#20 SAE (1 5/8" - 12) Straight Thread
X	#24 SAE (1 7/8" - 12) Straight Thread
Y	#30 SAE (2 1/2" - 12) Straight Thread

### 6 (Displacement)

Order Code	Cm <sup>3</sup> /In <sup>3</sup>	Order Code	Cm <sup>3</sup> /In <sup>3</sup>
58	58/3.54	104	104/6.30
68	68/4.13	113	113/6.88
80	80/4.91	129	129/7.86
91	91/5.51	145	145/8.84
97	97/5.89	161	161/9.82

### 7 (Outlet and Bypass Port Connections)

Order Code	Description
C	1.250", SAE 4-Bolt Split Flange
CM	1.250", 4-Bolt Metric Split Flange (M10 x 1.50" Threads)
D	1.50", SAE 4-Bolt Split Flange
DM	1.50", 4-Bolt Metric Split Flange (M12 x 1.75" Threads)
V	#16 SAE (1.3125" - 12) Straight Thread
W	#20 SAE (1 5/8" - 12) Straight Thread
X	#24 SAE (1 7/8" - 12) Straight Thread

NOTE: The same port size must be selected for both the outlet and bypass ports.

Load Sense Port:	7/16-20 for all sizes
------------------	-----------------------

\*\* Multiple pumps available. Contact factory.

EXAMPLE:

**(F3)- F-30LS-4- E-91-D-A-1-B-L-30**

1	2	3	4	5	6	7	8	9	10	11	12
Special Seals	Pump Type	Series	Front Cover	Inlet Port	Displacement	Outlet Bypass Port	Shaft Seal	Shaft Type	Unload Pressure	Shaft Rotation	R. V. Setting

### 8 (Shaft Seal)

Order Code	Description
A	Single
B	Double
J	Double, Outer Inverted
X	None

### 9 (Shaft Types)

Order Code	Description
1	SAE "C" Straight Keyed, 1.250" Dia., 1.875" Ext.
12	SAE "C" 14-Tooth Spline (Flat Root-Side Fit)
18 *	SAE "B" 13-Tooth Spline (Flat Root-Side Fit)

\* Only available for Displacements 58 & 68.

Contact factory for requirements not listed above.

### 10 (Unload Pressure)

Order Code	Description
A	30 PSI Standard Bypass Spring
B*	60 PSI Bypass Spring

\* "B" unload spring option required when system contains a high rate compensator spring in the directional control valve.

### 11 (Shaft Rotation)

Order Code	Description
L	Counterclockwise
Omit	Clockwise

### 12 (Relief Valve Setting)

Order Code	Description
10	1000 PSI (69 BAR)
12	1250 PSI (86 BAR)
15	1500 PSI (103 BAR)
17	1750 PSI (121 BAR)
20	2000 PSI (138 BAR)
22	2250 PSI (155 BAR)
25	2500 PSI (172 BAR)
27	2750 PSI (190 BAR)

### 13 (Load Sense Options)

Order Code	Description
A	Standard Load Sense
B	12 VDC with Spade Connector

### 14 (Design Designation)

Order Code	Description
20	Modification Level
	Design Level

Standard factory relief valve setting is 2500 PSI (172 BAR).  
Contact factory for other settings.



## PRODUCT RANGE

He Power Packs  
12/24/48 VDC 0.8 - 3.5 kW and 0.75 - 3 kW AC modular power packs

Pressure Switches  
5 - 350 bar connecting / disconnecting

He Classic Power Packs  
12/24/48 VDC modular powerpacks in weatherproof boxes

W100 Hydraulic Pumps  
0.5 - 2.0 cc/section, 227 bar

W300 Hydraulic Pumps  
0.8 - 5.7 cc/section, 230 bar

W600 Hydraulic Pumps  
4 - 12 cc/section, 276 bar

WM600 Hydraulic Motors  
4 - 12 cc/section, 276 bar

W900 Hydraulic Pumps  
5 - 31 cc/section, 276 bar

WM900 Hydraulic Motors  
5 - 31 cc/section, 276 bar

WQ900 The Quiet Pump  
5 - 27 cc/section, 230 bar

W1500 Hydraulic Pumps  
19 - 50 cc/section, 276 bar

WM1500 Hydraulic Motors  
19 - 50 cc/section, 276 bar

F25 Hydraulic Pumps  
23 - 87 cc/section, 250 bar

FM25 Hydraulic Motors  
23 - 87 cc/section, 250 bar

GPA Internal Gear Pumps  
1.7 - 63 cc/section, 100 bar

GC Hydraulic Pumps/Fluid Motors  
1.06 - 11.65 cc/section, 276 bar

II-Stage Hydraulic Pumps  
4.2 - 22.8 cc/section, 276 bar

Rotary Flow Dividers  
3.8 - 13.3 cc/section, 300 bar

D Hydraulic Pumps  
3.8 - 22.9 cc/section, 207 bar

H Hydraulic Pumps  
9.8 - 39.4 cc/section, 207 bar

F15 Hydraulic Pumps  
19 - 50 cc/section, 276 bar

F20/F30 Hydraulic Pumps  
23 - 161 cc/section, 276 bar

FM20/FM30 Hydraulic Motors  
23 - 161 cc/section, 276 bar

Transmission Pumps

Fuel Pumps

F20LS/F30LS 4 / 08

www.haldex.com



Haldex Hydraulics Corp.  
2222 15th Street  
ROCKFORD, IL 61104  
USA  
Tel: +1-815 398 4400  
Fax: +1-815 398 5977  
E-mail: info.hydraulics.us@haldex.com

Haldex Hydraulics Corp.  
214 James Farm Road  
STATESVILLE, NC 28625  
USA  
Tel: +1-704 873 2587  
Fax: +1-704 878 0530  
E-mail: info.hydraulics.us@haldex.com

Haldex Hydraulics AB  
Box 95  
SE-280 40 SK. FAGERHULT  
Sweden  
Tel: +46-433 32400  
Fax: +46-433 30546  
E-mail: info.hydraulics.eu@haldex.com

Haldex Hydraulics AB  
Box 511  
SE-195 25 ARLANDASTAD  
Sweden  
Tel: +46-8 591 288 50  
Fax: +46-8 591 288 60  
E-mail: info.hydraulics.eu@haldex.com

Haldex Hydraulics GmbH  
Postfach 1507  
D-95014 HOF  
Germany  
Tel: +49-9281 895-0  
Fax: +49-9281 87133  
E-mail: info.hydraulics.eu@haldex.com

Haldex International Trading  
(Shanghai) Co. Ltd.  
16 A. Zhao Feng World Trade Building  
No. 369 Jiang Su Road  
SHANGHAI 200050  
P. R. China  
Tel: +86 21 5240 0338  
Fax: +86 21 5240 0177

Haldex Vehicle Products  
(Suzhou) Co. Ltd.  
LongPu Road No. 6  
Suzhou Industrial Park  
SUZHOU 215126  
P. R. China  
Tel: +86 512 8885 5301  
Fax: +86 521 8765 6066

Haldex Hydraulics (Qingzhou) Co. Ltd.  
No. 1789, Shidai Yi Road  
Economy Development Zone  
QINGZHOU 262500  
P. R. China  
Tel: +86 536 3296 598  
Fax: +86 536 3296 410



Haldex (www.haldex.com), headquartered in Stockholm, Sweden, is a provider of proprietary and innovative solutions to the global vehicle industry, with focus on products in vehicles that enhance safety, environment and vehicle dynamics. Haldex is listed on the Stockholm Stock Exchange and has annual sales of nearly 8 billion SEK with 6,000 employees.